

Example of Hydraulic Scheme – Inox Maxi SSB DHW Buffer Cylinder

Typical unvented water heater and buffer vessel schematic

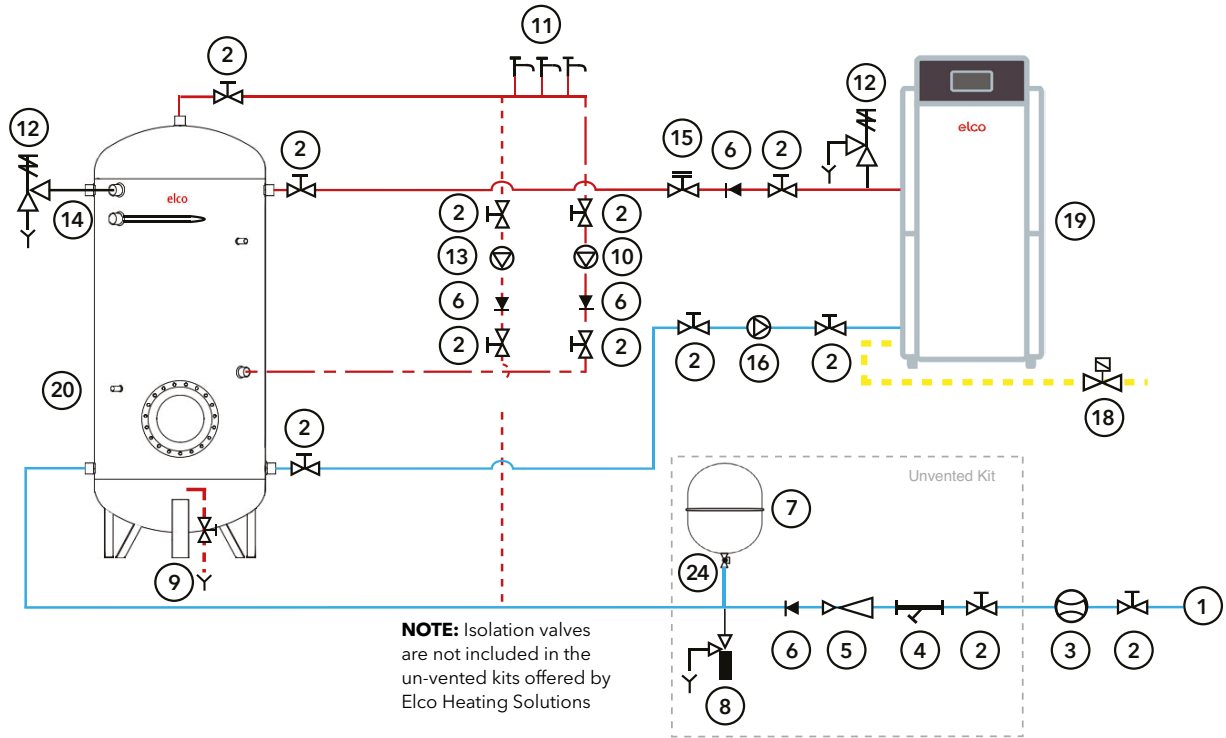

- | | | |
|----------------------------|---|-----------------------------|
| 1. Cold water supply | 9. Drain | 18. Gas shut-off valve |
| 2. Isolation valve | 10. DHW secondary re-circulation pump | 19. TRIGON® XL Water Heater |
| 3. Water meter | 11. Hot water outlets | 20. SSB buffer vessel |
| 4. Strainer | 12. Temperature and pressure relief valve | 24. Lockshield valve |
| 5. Pressure limiting valve | 13. De-stratification pump | |
| 6. Non-return valve | 14. Immersion heater | |
| 7. Expansion vessel | 15. Double regulating valve | |
| 8. Expansion relief valve | 16. DHW Primary Circulation Pump | |

For more schematics please refer to the Installation and Operation manual or contact ELCO Heating Solutions

These illustrations are designed to provide general guidance on the hydraulic scheme and should not be considered as an installation drawing.

Clearances

