

TECHNICAL SUBMISSION

Inox Maxi SSB 2000 Litre Vertical 316L Stainless Steel Buffer Vessel

General Description:

The Inox Maxi SSB 2000 Litre Vertical 316L Stainless Steel buffer vessel is a floor standing, stainless steel, domestic hot water buffer vessel.

The cylinder is suitable for use in open vented applications, or un-vented applications with an optional/additional un-vented kit. The potable water expansion vessel supplied with the matched un-vented kit has a nominal allowance for the capacity of the secondary hot water pipe-work. This allowance is approximately 17.5% of the capacity of the cylinder. If the volume of the secondary pipe-work is likely to exceed this figure, an appropriately sized additional expansion vessel must also be installed.

As the cylinder is resistant to corrosion, there are no sacrificial anodes to check or change, or the requirement for a powered active protection system to monitor.

The cylinders are supplied with a matched temperature and pressure relief valve as standard. The cylinder is also supplied with a control and limit thermostat for control interaction with the heat source. There are suitably positioned sensor pockets and a tapping for an optional element if required

The cylinder body is manufactured from 316L stainless steel and is insulated with high thermal insulation with ecological polyurethane hard foam, with a soft NOFIRE polyester fleece with high thermal insulation. The insulation is fire resistant class B-s2d0 according to EN 13501.

The cylinder body carries a five year warranty against material and manufacture faults. All other components carry a one year warranty against material and manufacture faults.



Technical Data:

Calorifier Model	SSB 2000 Stainless Steel Buffer Vessel	
Energy efficiency ¹ 	C	
Nominal Capacity	2018	Litres
Maximum working temperature	95	°C
Maximum secondary operating pressure	6	Bar
Weight empty/full	340/2358	kg

*Primary flow temperature 80°C

¹Energy Efficiency Class  Hot water storage tanks according to Directive 2010/30/EU and Regulation EU812/2013

Dimensions:

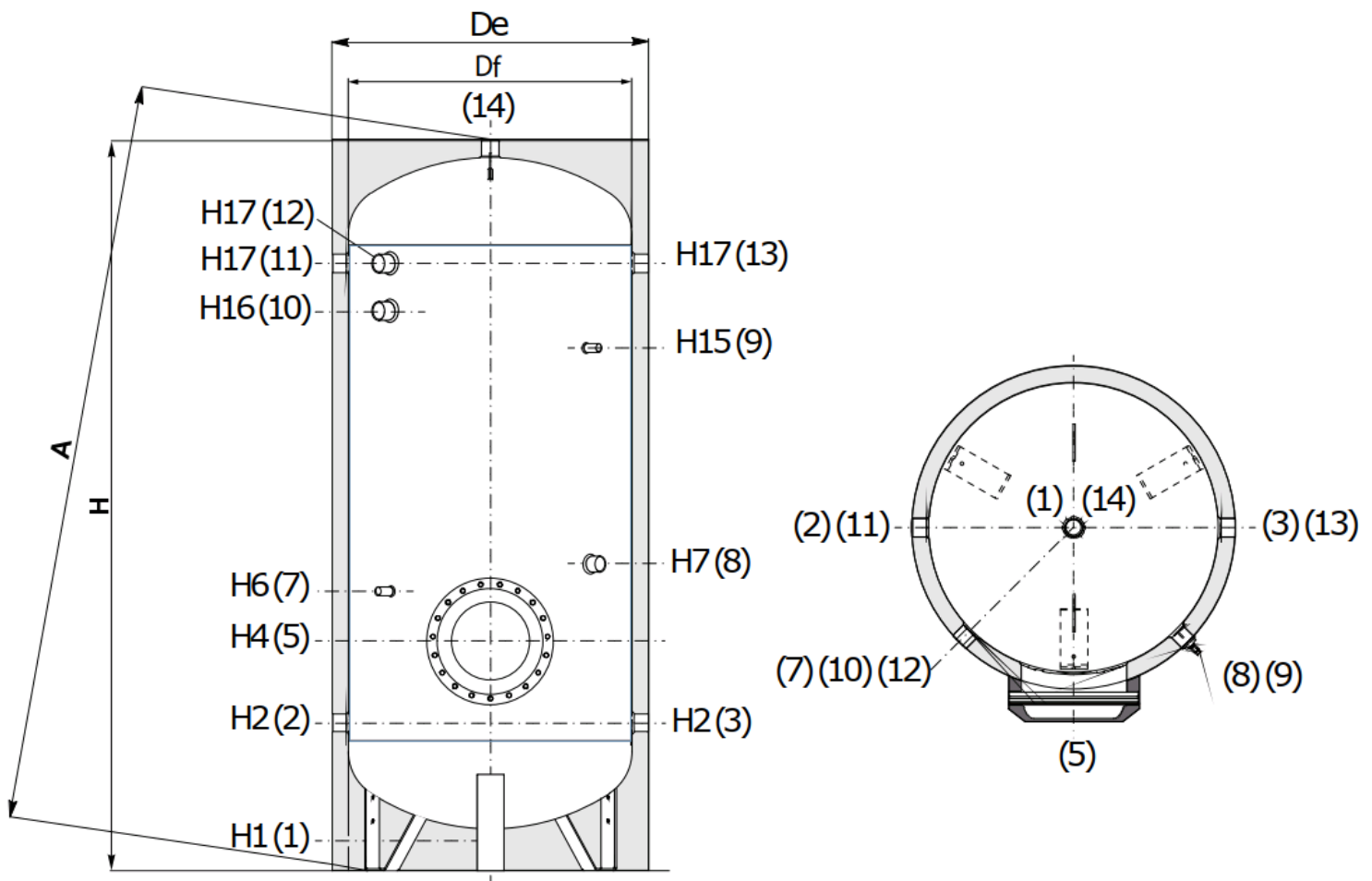

SSB 2000	Df	De	H	A	H1	H2	H4	H6	H7	H15	H16	H17	5
	1250	1470	2119	2205	134	529	574	714	1004	1524	1473	1629	∅e 240 mm

All dimensions are in mm unless stated otherwise.

Connections:

SSB 2000	1	2, 3, 11, 13	7 & 9	8	10	12	14
	1"	2"	½"	1 ¼"	2"	2"	2"