

Examples of hydraulic schemes - Inox-Maxi SSC1

Typical DHW schematic with a single coil calorifier SSC1 and TRIGON® XL gas fired boiler and 1 heating circuit with 3 way mixing valve

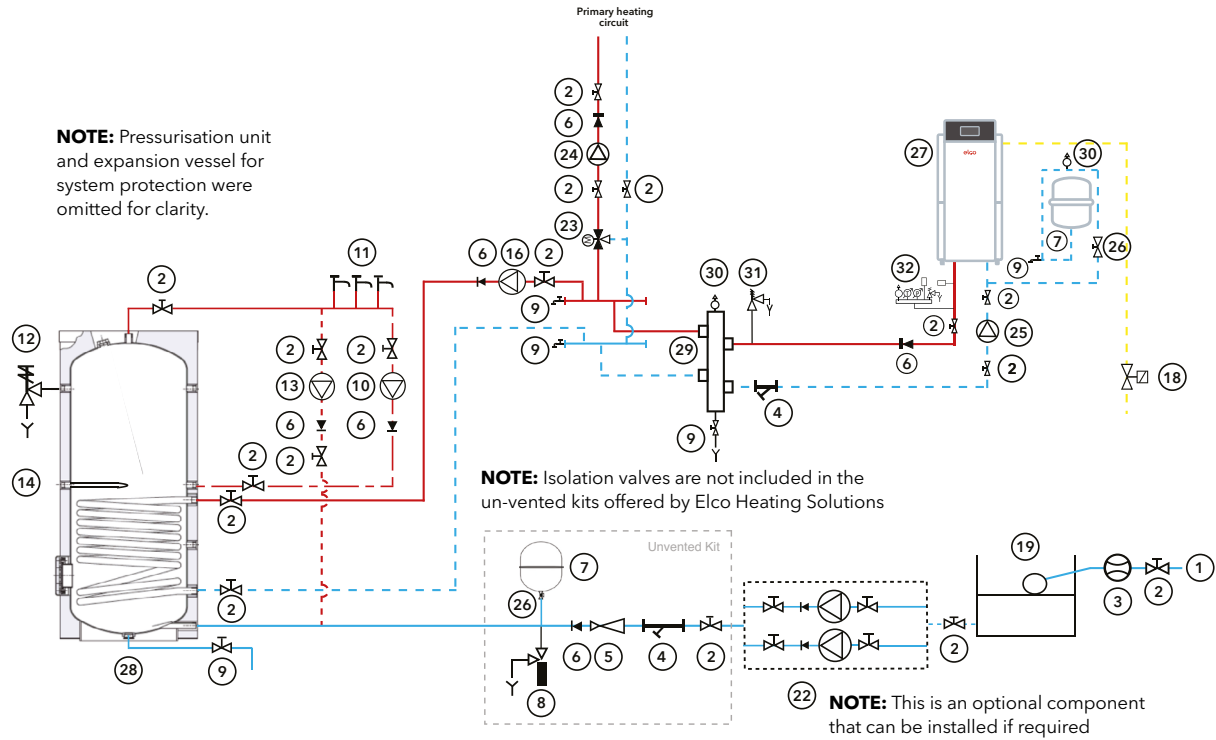

- | | | |
|----------------------------|-------------------------------------------|-------------------------------------|
| 1. Cold water supply | 10. DHW secondary re-circulation pump | 23. 3 Way motorised valve |
| 2. Isolation valve | 11. Hot water outlets | 24. Heating circuit pump |
| 3. Water meter | 12. Temperature and pressure relief valve | 25. Boiler primary circulating pump |
| 4. Strainer | 13. De-stratification pump | 26. Lockshield valve |
| 5. Pressure limiting valve | 14. Immersion heater | 27. TRIGON® XL boiler |
| 6. Non-return valve | 16. Primary DHW circulation pump | 28. SSC1 single coil calorifier |
| 7. Expansion vessel | 18. Gas shut-off valve | 29. Low loss header |
| 8. Expansion relief valve | 19. Cold water storage tank | 30. Automatic air vent |
| 9. Drain | 22. Cold water booster pump set | 31. System safety valve |
| | | 32. Boiler safety group |

For more schematics please refer to the Installation and Operation manual or contact ELCO Heating Solutions

These illustrations are designed to provide general guidance on the hydraulic scheme and should not be considered as an installation drawing.

Clearances

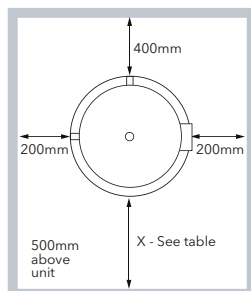

Inox-Maxi SSC1	500	800	1000	1300	1500	2000
X (mm)	750	1010	1020	1210	1260	1510