

Examples of hydraulic schemes - Polywarm PWC1

Typical DHW schematic with a single coil calorifier PWC1 and 2 THISION® L ECO gas fired boilers and 1 heating circuit with 3 way mixing valve

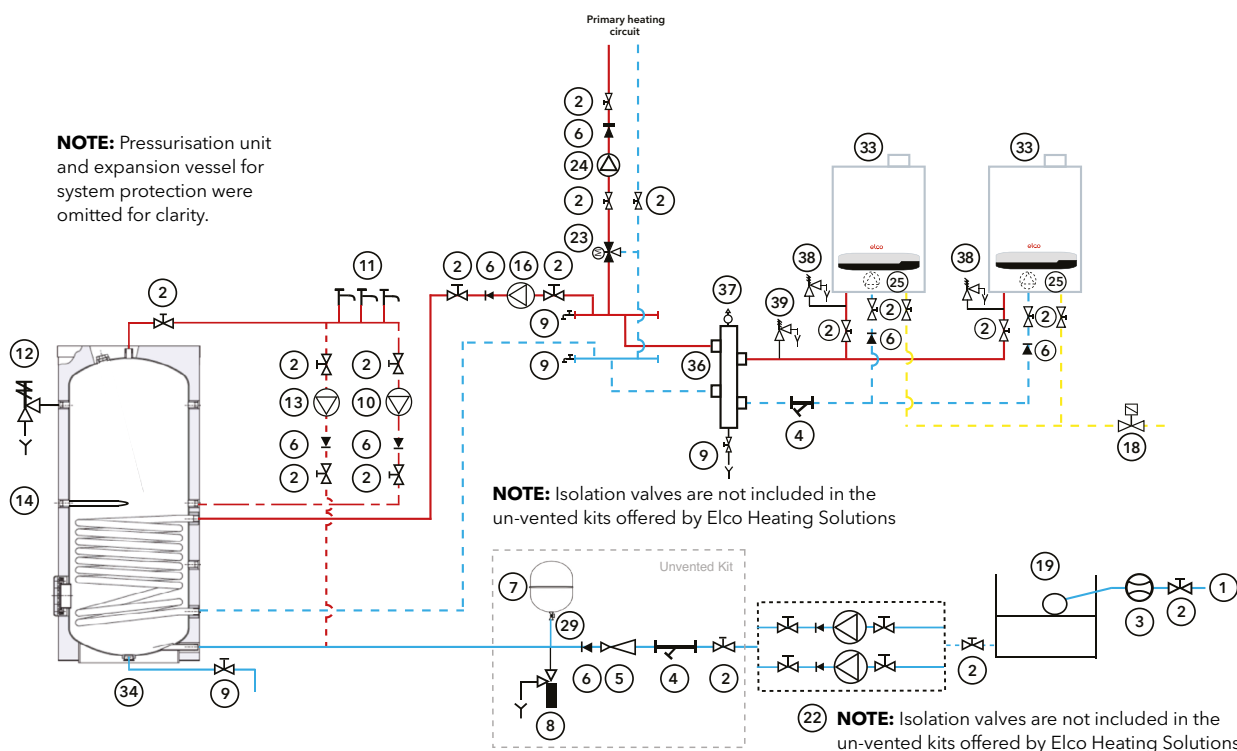

- | | | |
|----------------------------|---|---------------------------------|
| 1. Cold water supply | 10. DHW secondary re-circulation pump | 23. 3 Way motorised valve |
| 2. Isolation valve | 11. Hot water outlets | 24. Heating circuit pump |
| 3. Water meter | 12. Temperature and pressure relief valve | 25. Boiler primary pump |
| 4. Strainer | 13. De-stratification pump | 29. Lockshield valve |
| 5. Pressure limiting valve | 14. Immersion heater | 33. THISION® L ECO Boiler |
| 6. Non-return valve | 16. DHW primary circulation pump | 34. PWC1 single coil calorifier |
| 7. Expansion vessel | 18. Gas shut-off valve | 36. Low loss header |
| 8. Expansion relief valve | 19. Cold water storage tank | 37. Automatic air vent |
| 9. Drain | 22. Cold water booster pump set | 38. Safety valve |
| | | 39. System safety valve |

For more schematics please refer to the Installation and Operation manual or contact ELCO Heating Solutions

These illustrations are designed to provide general guidance on the hydraulic scheme and should not be considered as an installation drawing.

Clearances

