

Installation schematics – Polywarm PWB DHW Buffer Cylinder

Typical NHREC Gas Water Heater and 1 additional SSB or PWB DHW buffer vessels schematic

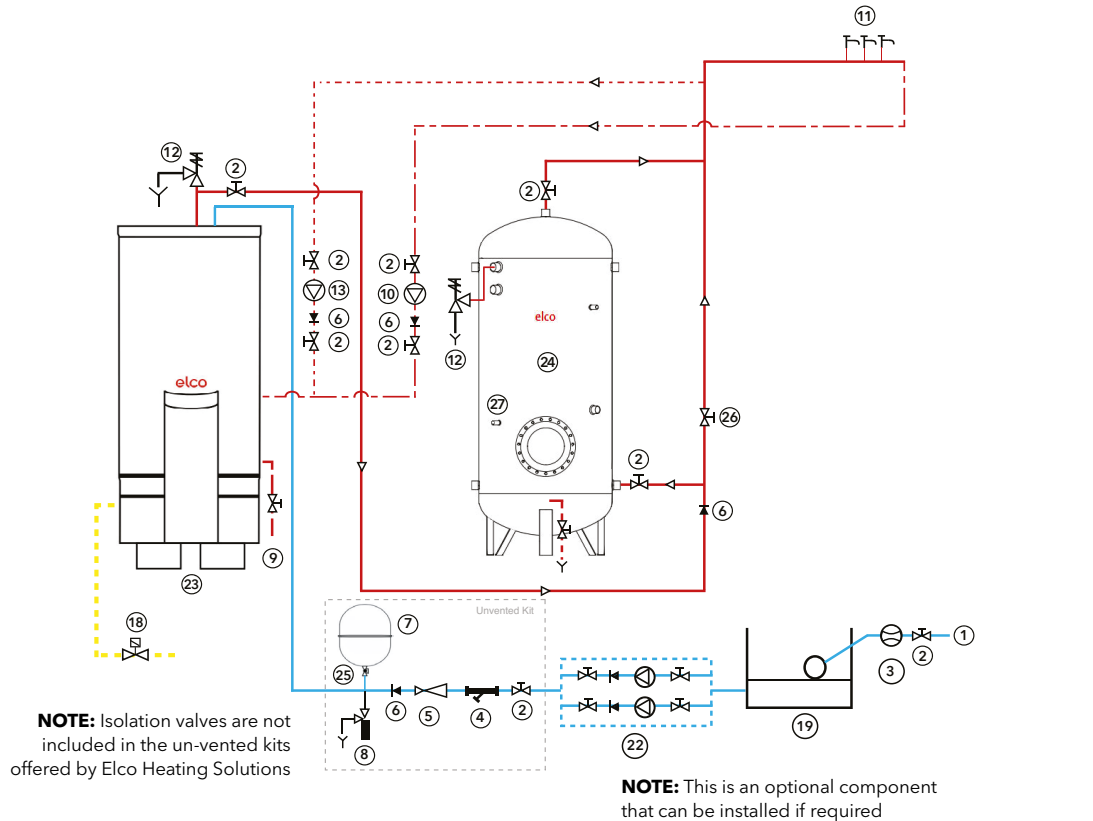

- | | | |
|----------------------------|---|-----------------------------------|
| 1. Cold water supply | 8. Expansion relief valve | 19. Cold water storage tank |
| 2. Isolation valve | 9. Drain | 22. Cold water booster pump set |
| 3. Water meter | 10. DHW secondary re-circulation pump | 23. NHREC water heater |
| 4. Strainer | 11. Hot water outlets | 24. PWB buffer vessel |
| 5. Pressure limiting valve | 12. Temperature and pressure relief valve | 25. Lockshield valve |
| 6. Non-return valve | 13. Pump for Charging PWB buffer vessel | 26. Normally closed valve |
| 7. Expansion vessel | 18. Gas shut-off valve | 27. Thermostat to control pump 13 |

For more schematics please refer to the Installation and Operation manual or contact ELCO Heating Solutions

These illustrations are designed to provide general guidance on the hydraulic scheme and should not be considered as an installation drawing.

Clearances

