

TECHNICAL SUBMISSION

TRIGON XL H2 300 IND DHW Generator Gas Fired Ultra Low NOx

General Description:

The TRIGON XL H2 300 IND, is one model in a range of seven DHW generators. The appliance incorporate a heat exchanger manufactured from stainless steel and a fully modulating, ultra-low NOx combustion system. The range of seven models provide a heat transfer from **142kW to 540kW @ ΔT 20°C**. The figures are based on maximum modulation rates only. The burners are water cooled, to maximise heat transfer and reduce heat losses. This factor, combined with precise gas to air mixing, results in **extremely low environmental impact. NOx emissions of 24.3mg/kWh (BS EN 15502)**. The water generator can achieve a **Gross Thermal Efficiency of up-to 98.4% at 30% modulation rate**. The calculated **Gross average annual efficiency (RAL 40/30°C) is 99.4%**. This figure is a calculated average based on tests completed at a modulation rate of 63%, 48%, 39% 30% and 13% and is **in accordance with DIN4702/8**.

The TRIGON XL H2 300 IND represents a significant step forward in heating technology, providing a continuous supply of hot water at an efficient recovery rate. With extremely flexible configurations, clever design and the range of models available, this water heater is perfect for a variety of commercial applications. Typical example being industrial processes such as manufacturing plant and cleaning/sterilization processes due to the high set-point temperature.

By combining the unique premix burner with the stainless steel heat exchanger, the appliance is built for challenging working conditions. The appliance is specifically designed for optimised efficiency and performance during its entire lifetime.

The DHW generator is supplied in one piece, with a fitted robust and stylish outer casing fabricated from stove enabled steel sheet. If access to the plant room is difficult, then our engineers can dismantle the boiler into manageable sections, transport the parts to the desired location and then re-assemble the boilers. This service is a chargeable extra.

The DHW generator is designed to operate with a DHW storage cylinder for optimised performance. The nominal flow rate must be maintained to prevent over-temperature faults. The nominal flow rate is designed to provide a 17°C temperature rise, with each pass through the heat exchanger.



The TRIGON XL H2 300 IND DHW generator is certified as being H2 ready. **This means that the appliance is suitable for use with a fuel supply consisting of up-to a maximum of a 20% hydrogen and 80% natural gas.** The same appliance can operate using natural gas only, with no modifications.

Warranty: To activate warranty, you must **register your product** within six months of the purchase date. This can be completed by telephone or email.

Tele: **0333 240 8777 option One** - New product registrations.

e-mail: **customer.service.uk@ariston.com**

The following information must be provided:

Appliance serial number

Purchase date

Installation date

Site contact name, email address and telephone number

Product installation address.

On the condition that the product has been installed to manufacturers instructions and the warranty terms and conditions have not been compromised, the standard warranty term for the **TRIGON XL boilers** is **two years** from date of purchase.

All products that are **not registered**, will have a **one year** warranty period and this will cover **material and manufacture Fault**, subject to the product being installed to manufacturers instructions.

Technical Data:

TRIGON XL H2 300 IND DHW Generator		Units	Data
Water	Continuous delivery @ 44°C ΔT	litres/hour	5586
	First hour delivery @ 44°C ΔT	litres	Continuous delivery (litres/hour) @44°C ΔT plus stored volume
	Continuous delivery @ 50°C ΔT	litres/hour	4916
	First hour delivery @ 50°C ΔT	litres	Continuous delivery (litres/hour) @50°C ΔT plus stored volume
	Continuous delivery @ 80°C ΔT	litres/hour	3076
	First hour delivery @ 80°C ΔT	litres	Continuous delivery (litres/hour) @56°C ΔT plus stored volume
	Set-point temperature (maximum)	°C	90
	Water generator operating pressure (min/max)	bar	1/8
Energy	Gross efficiency @ 100%/30%/annual RAL40/30	%	88.5/98.4/99.4
	Standby losses (constant temp 50°C)	kW/24hr	0.3
	Gas input Nominal	kW	323
	Net input - maximum	kW	291.0
	Output to water (min/max)	kW	56.5/285.7
	Gas consumption G20 (10.9 kWh/m ³) (min/max)	m ³ /h	5.3/26.7
	Gas consumption G25 (8.34 kWh/m ³) (min/max)	m ³ /h	7.0/34.9
	Gas consumption G31 – LPG (12.8 kWh/kg) (min/max)	Kg/h	4.5/22.7
	Required nominal gas pressure G20/G25/G31	mbar	20/25/30 to 50
	Maximum gas pressure	mbar	50
	Sound power (LWA)	dB(A)	70.3
Flue	Approximate flue gas volume (min/max)	m ³ /h	77/377
	Combustion fan – residual pressure (min/max)	Pa	10/160
	Flue gas temperature (min/max)	°C	30/75
	NOx emissions (BS EN 15502)	mg/kWh	24.3
Electrical	Recommended electrical protection	Amps	16
	Run current boiler only (min/max)	Amps	0.21/1.0
	Electrical supply	V/Hz	230/50
	Voltage tolerance (min/max)	V	216.2/253
Misc	Weight empty/full	kg	434/494
	Approximate shipping weight	kg	449

Dimensions & Clearances:

TRIGON® XL WH 300, 400, 500 & 570

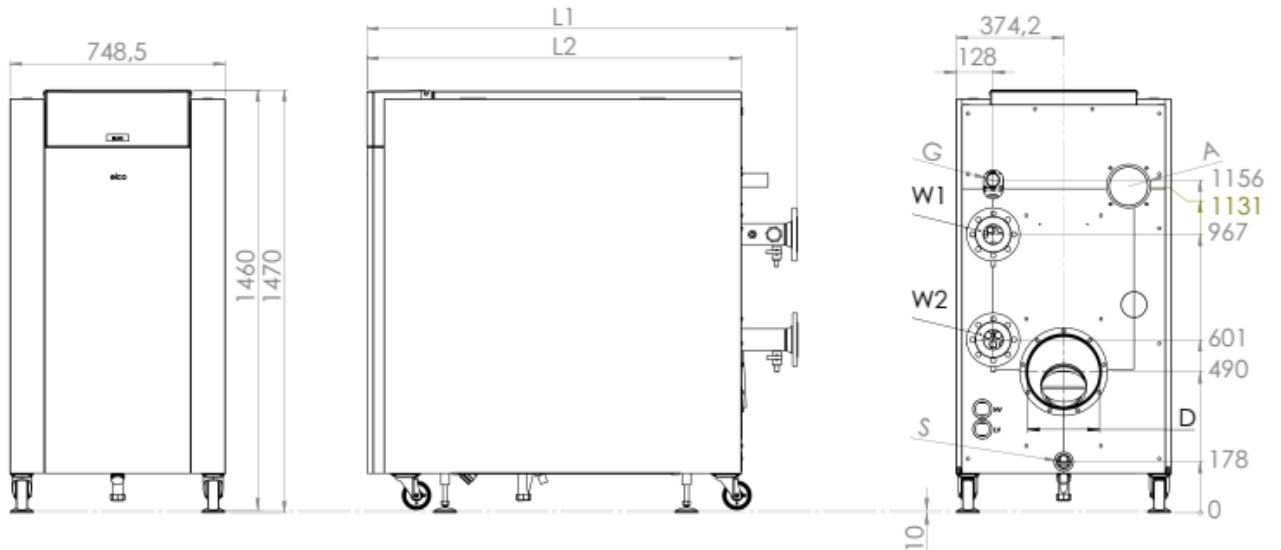

To optimize the position of the boiler in the room it is possible to exchange the position of the electrodes from the right side of the boiler to the left side of the boiler.

This also means that the required space as indicated in the picture will be mirrored.

Normal: Left 250mm / Right 450mm
Modified: Left 450mm / Right 250mm

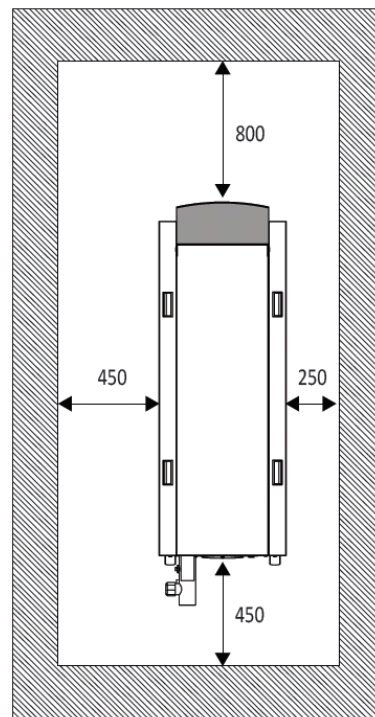

Dimensions mm	TRIGON XL H2 300 IND
L1	1348
L2	1152
A - (combustion air supply)	130Ø
G - (gas connection)	1½"
D - (flue gas exhaust)	200Ø
S - (condensate drain)	32
W1 - (primary flow)	DN65 PN16
W2 - (primary return)	DN65 PN16

General Guidance Schematics:

System 1: water heater with buffer tank

Water heater connected to a buffer tank, with the cold water feed and recirculation line combined before returning to the buffer tank. This is the most common way to connect a water heater. Having the cold water feed combined with the recirculation line results in less start/stop sequences of the water heater and creates a stable temperature control in a normal hot water installation.

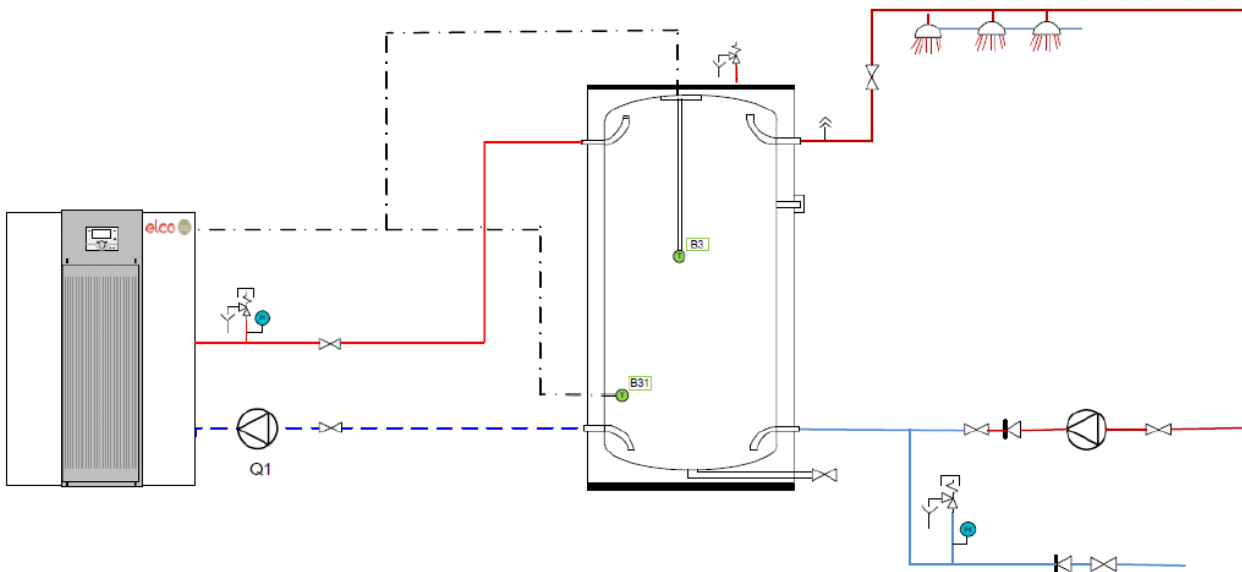

System 2: water heater cascade

When having a constant high demand of hot water, it's useful to install a high heater (or even a cascade of multiple water heaters) in combination with a small buffer tank. The Buffer tank is only covering the starting delay of the boilers, after that the boilers completely cover the hot water demand constantly.

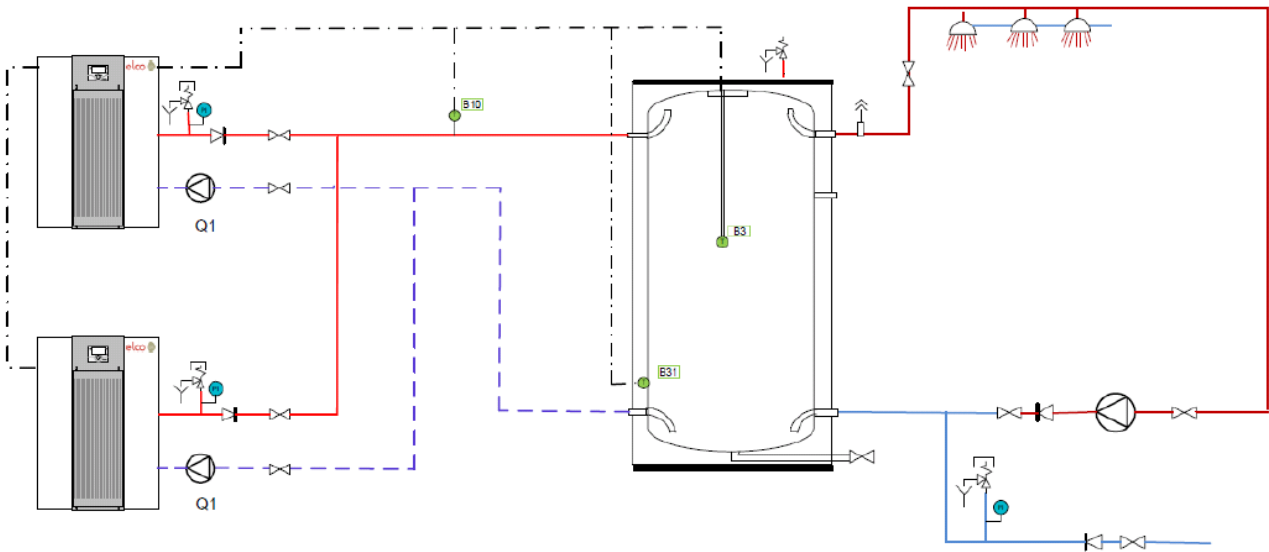

System 3: bypass water heater with buffer tank

This system is mainly used in industrial processes, where there is a requirement for direct increase of the water temperature with more than 17K, without having a constant demand. Without the buffer tank the bypass water heater would generate many starts and stops and have a restive regulation.

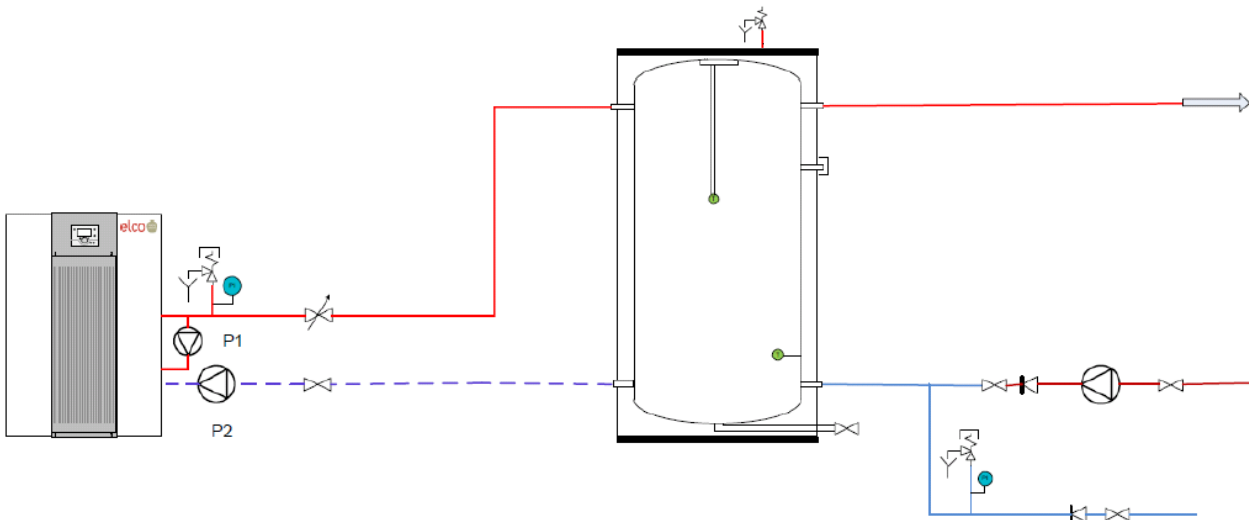

System 5: bypass water heater cascade with 2 buffer tanks

This system is mainly used in industrial processes, where there is a requirement for direct increase of the water temperature with more than 17K, without having a constant demand. Without the buffer tank the bypass water heater would generate many starts and stops and have a restive regulation.

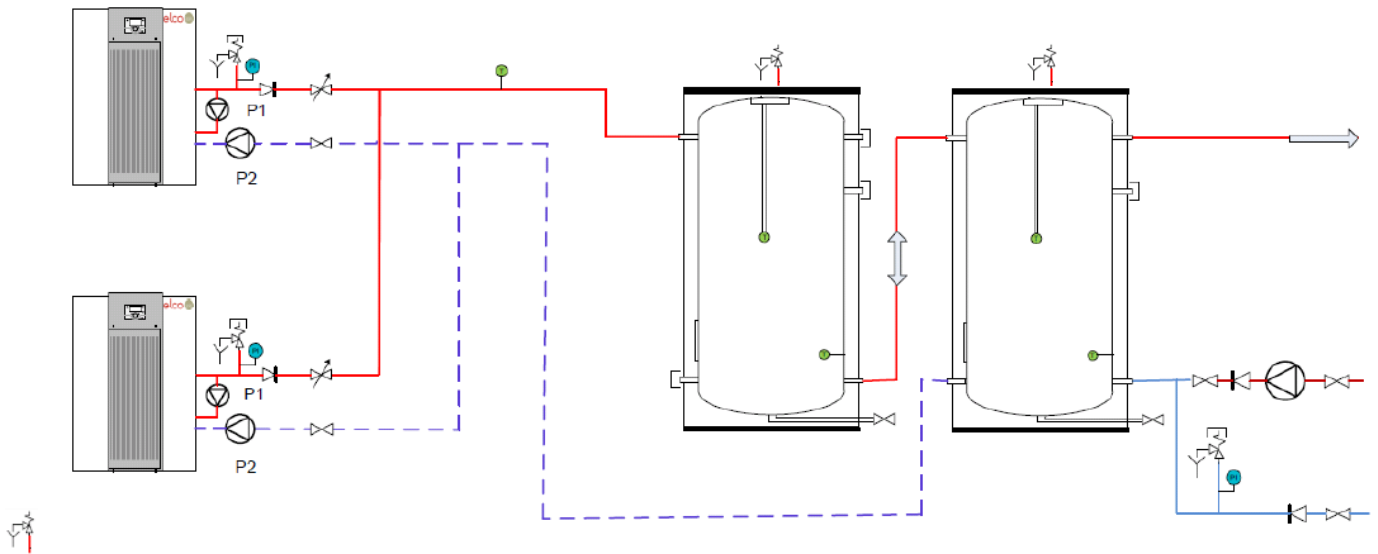

The schematics are for general guidance and do not show all necessary isolation valves. Further guidance is available from Elco Heating Solutions