

TECHNICAL SUBMISSION

TRIGON® L PLUS 200 Floor Standing Ultra Low NOx Condensing Boiler

General Description:

The TRIGON® L PLUS 200 H2 boiler is one of a range of seven floor standing, stainless steel, fully modulating, ultra-low NOx, gas fired high efficiency condensing boilers, with maximum outputs ranging between 56.9kW to 180.3kW @ 80/60°C ΔT. All TRIGON® L PLUS H2 boilers utilise a pre-mix combustion system, to provide precise gas to air mixing, resulting in extremely low environmental impact.

The TRIGON® L PLUS 200 H2 is tested to the requirement of BS EN 15502, with NOx annual emissions of 23.6mg/kWh. The appliance is therefore awarded the maximum two BREEAM credits. The modulation range is from 18.1kW to 180.3kW @ 80/60°C, increasing to 196.9kW when operating in full condensing mode. The boiler is calculated to have a Gross Seasonal Efficiency of 96.2% which meets with the efficiency criteria as set out in the Non-domestic Building Services Guide Compliance Guide 2010 Edition (with 2013 amendments).

The TRIGON® L PLUS H2 boilers are low water content appliance that offer compact dimensions with easy manoeuvrability via their cargo wheels. The boiler includes a comprehensive controller (HMI) that features integrated master-slave cascade functionality. Multiple boilers in a cascade installation can satisfy a large range of heat demands for commercial applications and provide security of service, with the added benefit of increased modulation ranges (turn-downs). There are additional kits to allow control of heating zones and provide hydraulic separation for the primary circuits. Elco Heating Solutions offer the optional communication gateway and this allows communication with building management systems using BACnet, LONworks, MODbus & KNX. Two way communication is possible allowing remedial alterations to be made from a remote location.

The boiler is supplied in one piece, with a fully insulated robust and stylish outer casing fabricated from stove enabled steel sheet, providing low standing heat loss. The boiler includes a primary modulating pump that is controlled to accurately match the flow rate requirement at the boiler heat exchanger, to the modulation rate of the burner. The combustion and primary flow systems include non-return valves for additional security of operation.

The TRIGON® L PLUS H2 boiler can be supplied with an optional backpack solution. This consists of a low loss header, or plate heat exchanger fitted to the rear of the boiler. Elco Heating Solutions also supply a fully integrated package consisting of single, or multiple boilers that offer compact dimensions, ease of installation and peace of mind.



The TRIGON L PLUS 200 H2 boiler is certified as being H2 ready. This means that the appliance is suitable for use with a fuel supply consisting of up-to a maximum of 20% hydrogen and 80% natural gas. The same appliance can operate using natural gas only, with no modifications



Compliance with Standards as appropriate with relevant sections of: Gas Appliance Directive 90/396/EEC & Boiler Efficiency Directive 92/42/EEC.

Warranty:

To activate warranty, you must **register your product** within six months of the purchase date. This can be completed by telephone or email.

Tele: **0333 240 8777 option One** - New product registrations.

e-mail: **customer.service.uk@ariston.com**

The following information must be provided:

Appliance serial number

Purchase date

Installation date

Site contact name, email address and telephone number

Product installation address.

On the condition that the product has been installed to manufacturers instructions and the warranty terms and conditions have not been compromised, the standard warranty term for the **TRIGON L PLUS boilers** is **seven years** from date of purchase.

All products that are **not registered**, will have a **one year** warranty period and this will cover **material and manufacture fault**, subject to the product being installed to manufacturers instructions.

Technical Data:

Boiler Model	TRIGON® L PLUS 200 H2	
Seasonal space heating efficiency class ¹	-	
Nominal heat output at 80/60°C	180.3	kW
Minimum heat output at 80/60°C	18.1	kW
Nominal heat output at 50/30°C	196.9	kW
Minimum heat output at 50/30°C	19.7	kW
Nominal heat input full load Net	184.5	kW
Minimum heat input full load Net	18.5	kW
Efficiency at 80/60°C full load Net/Gross	97.7/88	%
Efficiency at 50/30°C min load Net/Gross	107.0/96.4	%
Efficiency at 30°C return 30% load Net/Gross	108.9/98.1	%
Gross seasonal efficiency ²	96.2	%
Gas consumption max/min nat gas G20	19.52/1.95	m ³ /h
Gas consumption max/min LPG G31 *	15.11/1.51	kg/h
Gas inlet pressure max/min nat gas G20	25/17	mbar
Gas inlet pressure max/min LPG G31 *	57.5-42.5 / 35-25	Mbar
NOx annual emissions (EN 15502) ³	23.6	mg/kWh
BREEAM Credits ⁴	2	-
Flue gas temperature at 80/60°C full load	71	°C
Max permissible flue resistance	265	Pa
Water pressure max/min	6.0/1.0	bar
Maximum temperature setpoint	90	°C
Water flow at ΔT=20K	2.16	lit/sec
Residual head of pump at ΔT=20K	0	kPa
Water flow at ΔT=25K	1.72	lit/sec
Residual head of pump at ΔT=25K	15.66	kPa
Minimum water flow rate	0.22	lit/sec
Electrical connection	230	V
Electrical power consumption boiler 230V 50Hz Boiler including pump	450	W
Electrical power consumption boiler 230V 50Hz Boiler excluding pump	276	W
Sound Power Level	63.4	dB(A)
Weight (empty)	140	Kg
Water content	25.8	litres
Dimensions		
Water connections flow/return ⁵	R2"	-
Gas connection ⁶	R1½"	-
Flue gas connection concentric	-	mm
Room sealed using separate exhaust and combustion air supply	2 x 130	mm
Condensate connection	35.5	mm
Boiler depth	675	mm
Boiler width	690	mm
Boiler height (excluding connections)	1100	mm

- 1 In accordance with directive 2010/30/EU and regulation (EU) 813/2013
- 2 In accordance with equation 2 in the Non-Domestic Building Services Compliance Guide
- 3 NOx value are calculated on GCV
- 4 BREEAM UK New Construction 2018
- 5 With optional Water/Gas Connection Kit the connection sizes decrease to 1½"
- 6 With optional Water Gas Connection kit the connection size decreases to 1"
- * LPG models available from 2021

TRIGON® L PLUS 200 H2 Floor Standing Dimensions & Clearances:

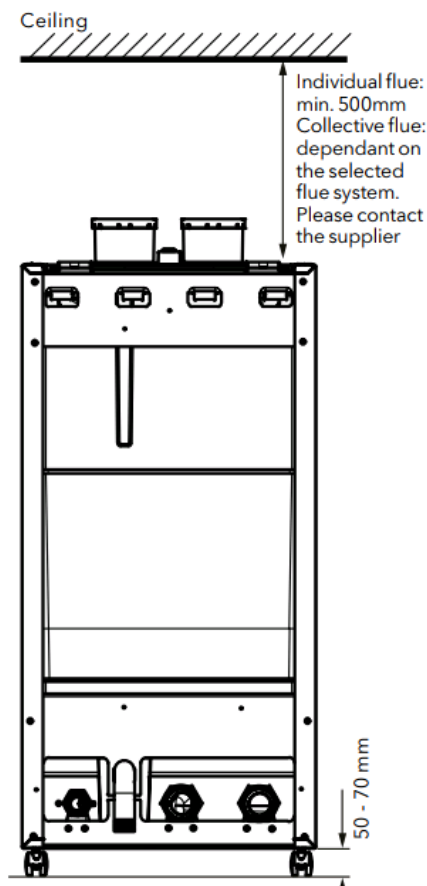
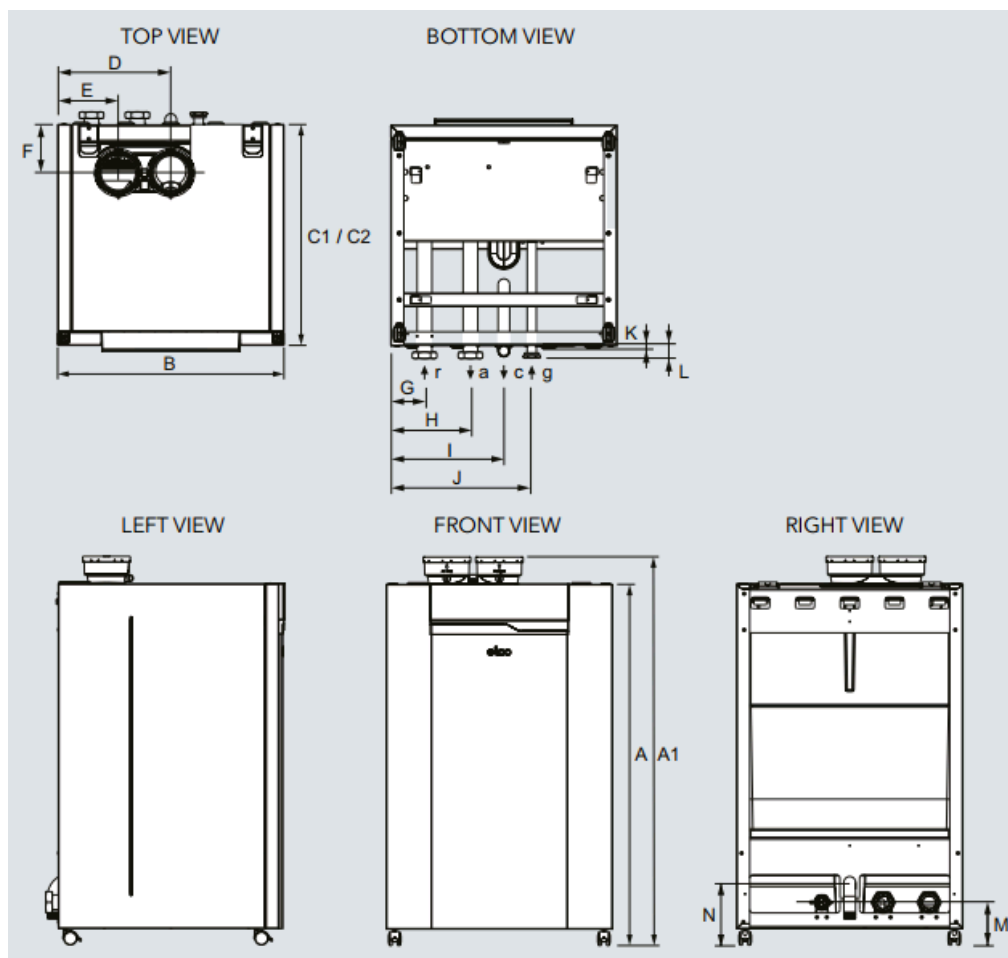

Dimensions		
Boiler height (A)	1100	mm
Boiler height with connections (A1)	1185	mm
Boiler width (B)	690	mm
Boiler depth C1/C2	675	mm
Flue Gas connection (D)	345	mm
Air intake connection (E)	185	mm
Air and flue gas connection (F)	150	mm
Boiler return connection (G)	103	mm
Boiler flow connection (H)	243	mm
Condensate Connection (I)	345	mm
Gas connection (J)	430	mm
Condensate connection (K)	15	mm
Boiler flow and return and gas connection (L)	35	mm
Boiler flow and return and gas connection (M)	130	mm
Condensate connection (N)	190	mm
Condensate connection (c)	35	mm
Parallel connection (air and flue gas)	2 x 130	mm
Boiler flow (a) Return (r)	2"	-
Gas connection (g)	1¼"	-

