

Gas condensing boiler  
Output: 150 – 570 kW



# TRIGON<sup>®</sup> XL

Compact, powerful performance



**READY FOR  
20% H<sub>2</sub>**

# TRIGON<sup>®</sup> XL – Flexible for every application

## A new standard

The TRIGON<sup>®</sup> XL represents a significant step forward in heating technology. With extremely flexible configurations, clever design and a range of models available, the boiler is perfect for a variety of commercial applications. It is time to discover the next generation of floor standing boiler.



## Comprehensive control features

A clear text display with integrated master-slave cascade functionality (up to 8 boilers) makes commissioning simple. Plus, upgradable module capacity provides straightforward connections for additional heating zones, solar system or external heat sources.



## Compact dimensions

All models are designed to pass through standard 760 mm wide doors. The range comprises 7 models with 2 widths.



## Flexible configurations

The inspection glass and ignition electrode can be fitted on either side of the boiler, allowing a more flexible boiler positioning on site.



## Wider applications

With an 8 bar max. water pressure, the boiler is compatible with higher buildings without the need for hydraulic system separation. Plus, a 30K flow/return temperature differential allows easier integration with district heating systems while maintaining optimum efficiency.

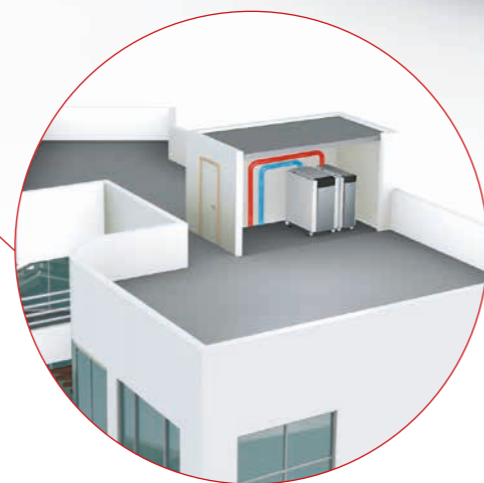

## Lightweight construction

By utilising low water content technology, the boiler can be easily installed on a rooftop - while also delivering superb response times and reduced running costs.



## Easy transportation

The boiler is supplied with cargo wheels, allowing it to be easily manoeuvred on site. After positioning, the boiler can be levelled and lifted from its cargo wheels by adjusting the feet.

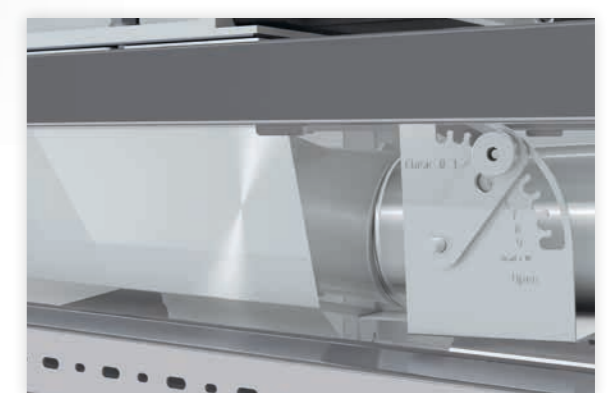

## Simple commissioning

An integrated flue gas damper and rear flue connection provides an installer-friendly arrangement.

# TRIGON® XL – Designed for challenging environments

## The burner

TRIGON® XL's advanced burner design provides the most technologically advanced and best performing unit on the market.

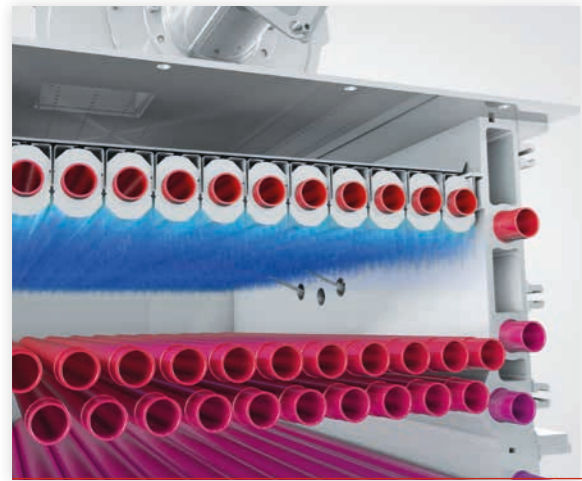

## Unique premix-burner system

A fully modulating, water-cooled cold flame burner utilises a one-of-a-kind system to provide reliable and robust performance.

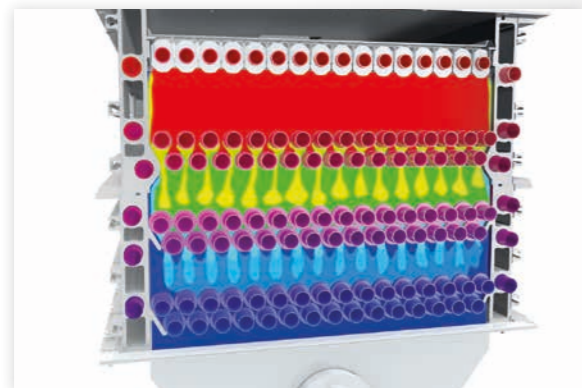

## Low emissions

The water-cooled cold flame burner and the optimised combustion zone achieve extremely low NOx and CO emissions, which already comply with NOx class 6 requirements.



## The heat exchanger

TRIGON® XL has a stainless steel heat exchanger built for challenging working conditions. It is specifically designed for optimised efficiency and performance during its entire lifetime.

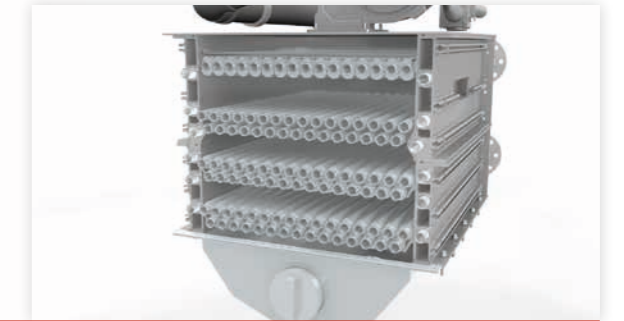

## Lifetime high efficiency

By combining the unique premix-burner/heat exchanger system with the optimised controls, TRIGON® XL provides impressive lifetime high efficiencies of up to 110%.

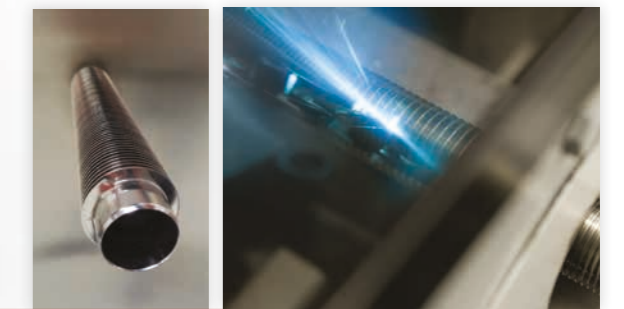

## Stainless steel laser welded fin tube

Advanced robot laser welding technology ensures superb heat transfer between the fins and the tube.

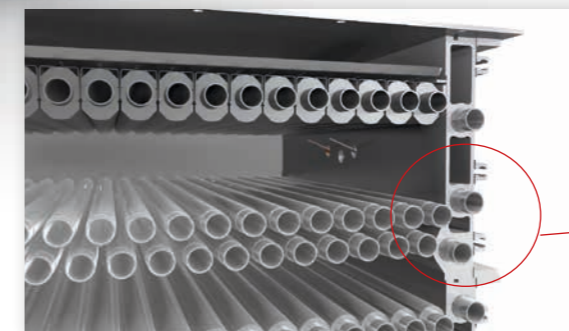

## Water cooled combustion chamber

A carefully engineered hydroforming process fixes the cooling tubes inside the sidewalls, providing the highest possible thermal conductivity.

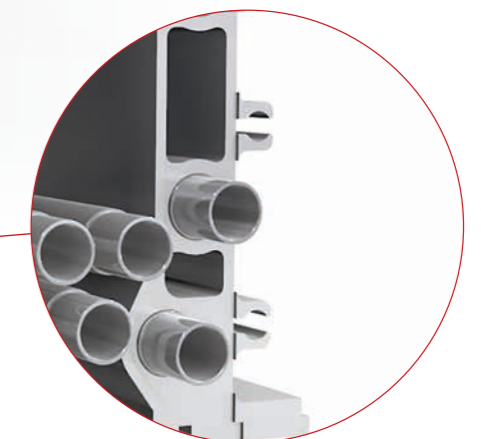

# Easy installation

## The smart modular concept

All TRIGON® XL boilers can be disassembled for easy on site handling. This also allows the boiler to be easily installed into buildings with restricted access.

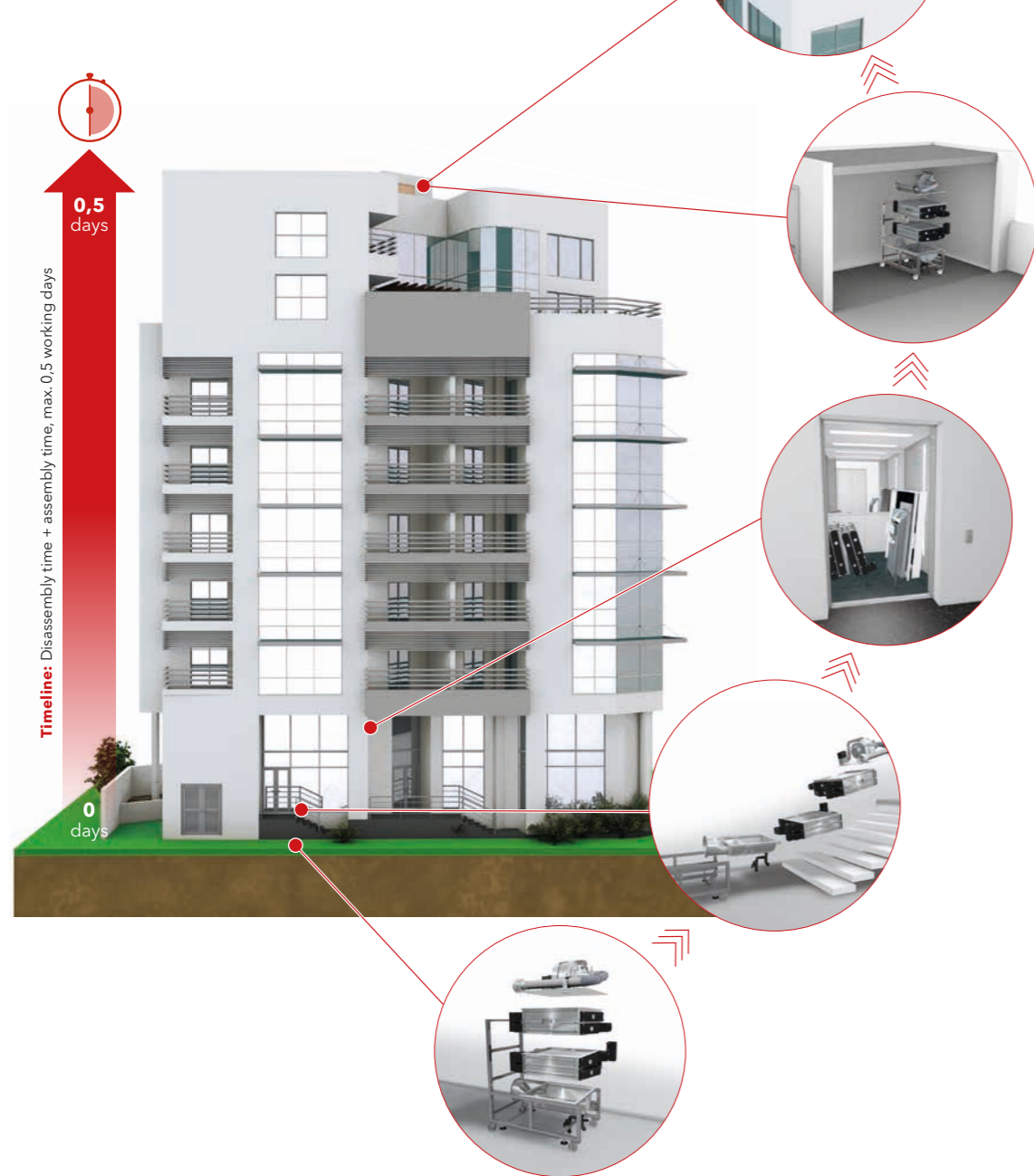

# Technical data TRIGON® XL

TRIGON® XL		150	200	250	300	400	500	570
Nominal heat output at 80/60 °C	kW	142,3	190,4	237,6	285,7	381,3	476,7	540,2
Minimum heat output at 80/60 °C	kW	31,3	42,0	47,0	56,5	75,2	94,6	120,0
Nominal heat output at 50/30 °C	kW	149,4	199,8	249,7	300,3	401,2	503,4	573,1
Minimum heat output at 50/30 °C	kW	35,2	47,1	52,9	63,6	85,0	106,1	133,4
Nominal heat input Hi full load	kW	145,0	194,0	242,0	291,0	388,0	485,0	550,0
Minimum heat input Hi min. load	kW	32,2	43,1	48,4	58,2	77,6	97,0	122,2
Efficiency at 80/60 °C full load	%	98,2	98,2	98,2	98,2	98,3	98,3	98,2
Efficiency at 40/30 °C min. load	%	110,0	110,0	110,3	110,3	110,3	110,3	110,5
Efficiency at 50/30 °C min. load	%	109,2	109,2	109,3	109,3	109,5	109,4	109,2
Annual efficiency (NNG 40/30 °C)	%	110,4	110,4	110,4	110,4	110,4	110,4	110,3
NOx level (EN15502)	mg/kWh	28	28	27	27	26	29	31
Flue gas temperature at 80/60 °C full load	°C	75	75	75	75	75	75	76
Max. permissible flue resistance	Pa	200	200	200	160	400	300	484
Water pressure max/min.	bar	8/1	8/1	8/1	8/1	8/1	8/1	8/1
Maximum temperature setpoint	°C	90	90	90	90	90	90	90
Water flow at ΔT=10K	m³/h	12,2	16,2	20,2	24,4	32,6	40,8	46,2
Hydraulic resistance at ΔT=10K	kPa	45	107	125	48	129	137	228
Water flow at ΔT=20K	m³/h	6,1	8,1	10,1	12,2	16,3	20,3	23,1
Hydraulic resistance at ΔT=20K	kPa	11,2	26,8	31,2	11,9	32,3	34,3	57,1
Water flow at ΔT=30K	m³/h	4,1	5,4	6,7	8,1	10,9	13,9	15,4
Hydraulic resistance at ΔT=30K	kPa	5	12	14	5	14	15	25
Electrical connection	V	230/400	230/400	230/400	230/400	230/400	230/400	230/400
Electrical power consumption (excl. pump)	W	176	267	286	230	504	620	676
Noise level	dB(A)	70,3	70,3	70,3	70,3	77,3	77,3	77,3
Water content	l	27,0	31,0	35,0	61,0	68,0	75,0	82,0
Weight (empty)	kg	290	332	336	434	496	540	595
<b>Dimensions</b>								
Water connections (W1/W2)	-	R2"	R2"	R2"	DN65 PN16	DN65 PN16	DN65 PN16	DN65 PN16
Gas connection (G)	-	R1½"	R1½"	R1½"	R1½"	R1½"	R2"	R2"
Flue gas connection (D)	mm	150	150	200	200	250	250	250
Air intake connection (A) (for room sealed use)	mm	130	130	130	130	130	150	150
Condensate connection (S)	mm	40	40	40	40	40	40	40
Boiler length with water connection (L1)	mm	1349	1499	1649	1348	1496	1646	1769
Boiler length without water connection (L1)	mm	1165	1315	1465	1152	1302	1452	1602



## Ready for green gases

The TRIGON® XL is already certified for operation with up to 20% hydrogen and biomethane today.

To guarantee that all boilers from the TRIGON® L PLUS, THISION® L PLUS, and TRIGON® XL series are equipped for the future, ELCO now provides a hydrogen retrofit kit specifically designed for these gas boilers already in the market.

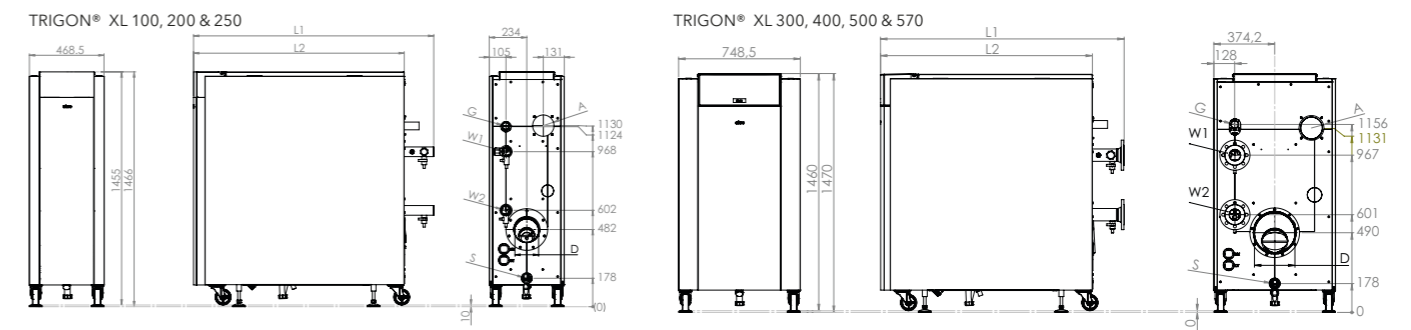

# ELCO – A partner you can rely on

As a specialist commercial heating manufacturer, you can rely on ELCO's extensive boiler expertise, from planning right through to servicing and maintenance via its network of trusted service partners. Our specially trained partners are available to help with the installation and commissioning of commercial boilers – offering their experience and assistance when you need it the most.



## Commissioning

Our specialist partners always work together with you in commissioning an ELCO boiler properly to provide a high quality service.



## First class service

Whether it is repairs, maintenance or troubleshooting, our service partners are there for you when you need them.



## Trained and certified service technicians

Our service partner technicians are specially trained, qualified and fully equipped with the tools required to ensure boilers are maintained to the highest standards.

## More information



[www.elco.co.uk](http://www.elco.co.uk)



[www.trigon-xl.com](http://www.trigon-xl.com)

