

TECHNICAL SUBMISSION

Trigon XL 300 H2 Gas Fired Ultra Low NOx Condensing Boiler

General Description:

The Trigon XL 300 H2 boiler is one of a range of seven floor standing, stainless steel, fully modulating, ultra-low NOx, gas fired condensing boilers, with maximum outputs ranging between **142.3kW to 540.2kW @ 80/60°C ΔT**. Trigon XL boilers use high efficiency pre-mix combustion system, water cooled burners which, combined with precise gas to air mixing, results in **extremely low environmental impact. NOx emissions of no more than 24.3mg/kWh**. The boiler is calculated to have a **Gross Seasonal Efficiency of 96.4%** which meets with the efficiency criteria as set out in the Non-domestic Building Services Guide Compliance Guide 2010 Edition (with 2011 amendments).

The Trigon XL 300 H2 boiler is supplied with the option to provide two system return connections. This facility enables the boiler to provide higher efficiency of operation, when serving both a high and low temperature heating circuit. The higher temperature return can be directed to miss the condensing heat exchanger and thus increase efficiency of operation, by preventing blending and a resultant increased system water return temperature to the condensing heat exchanger.

The Trigon XL H2 boilers are low water content appliance that offer compact dimensions with easy manoeuvrability. The boiler includes a comprehensive controller that features integrated master-slave cascade functionality. Multiple boilers in a cascade installation can satisfy a large range of heat demands for commercial buildings.

The boiler is supplied in one piece, with a fitted robust and stylish outer casing fabricated from stove enabled steel sheet. If access to the plant room is difficult, then our engineers can dismantle the boiler into manageable sections, transport the parts to the desired location and then re-assemble the boilers. This service is a chargeable extra.

The boiler is very versatile and capable of operating at design condition anywhere between **Δt 15 °C and Δt 30 °C**.

The TRIGON XL 300 H2 boiler is certified as being H2 ready. This means that the appliance is suitable for use with a fuel supply consisting of up-to a maximum of a 20% hydrogen and 80% natural gas. The same appliance can operate using natural gas only, with no modifications.



The TRIGON XL H2 150 H2 DHW generator is certified as being H2 ready. **This means that the appliance is suitable for use with a fuel supply consisting of up-to a maximum of a 20% hydrogen and 80% natural gas.** The same appliance can operate using natural gas only, with no modifications.

Warranty: To activate warranty, you must **register your product** within six months of the purchase date. This can be completed by telephone or email.

Tele: **0333 240 8777 option One** - New product registrations.

e-mail: **customer.service.uk@ariston.com**

The following information must be provided:

Appliance serial number

Purchase date

Installation date

Site contact name, email address and telephone number

Product installation address.

On the condition that the product has been installed to manufacturers instructions and the warranty terms and conditions have not been compromised, the standard warranty term for the **TRIGON XL boilers** is **two years** from date of purchase.

All products that are **not registered**, will have a **one year** warranty period and this will cover **material and manufacture Fault**, subject to the product being installed to manufacturers instructions.

Technical Data:

Boiler Model	Trigon XL 300 H2	
Nominal heat output at 80/60°C	285.7	kW
Minimum heat output at 80/60°C	56.5	kW
Nominal heat output at 40/30°C	303.3	kW
Minimum heat output at 40/30°C	64.2	kW
Nominal heat input full load Net	291.0	kW
Minimum heat input min load Net	58.2	kW
Efficiency at 80/60°C full load Net/Gross	98.2/88.5	%
Efficiency at 40/30°C min load Net/Gross	110.4/99.5	%
Efficiency at 30°C return 30% load Gross	98.3	%
Gross seasonal efficiency*	96.4	%
Gas consumption max/min nat gas G20	26.7/5.3	m ³ /h
Gas consumption max/min LPG G31	22.7/4.5	kg/h
Gas inlet pressure max/min nat gas G20	50/20	mbar
Gas inlet pressure max/min LPG G31	50/30	Mbar
NOx annual emissions (EN 15502)	24.3	mg/kWh
BREEAM Credits**	1	-
Flue gas temperature at 80/60°C full load	75	°C
Max permissible flue resistance	160	Pa
Water pressure max/min	8/1	bar
Maximum temperature setpoint	90	°C
Water flow at ΔT=11K	6.2	lit/sec
Hydraulic resistance at ΔT=11K	40	kPa
Water flow at ΔT=20K	3.4	lit/sec
Hydraulic resistance at ΔT=20K	12	kPa
Water flow at ΔT=30K	2.3	lit/sec
Hydraulic resistance at ΔT=30K	5	kPa
Electrical connection	230/400	V
Electrical power consumption boiler	230	W
Sound Power Level	70.3	dB(A)
Weight (empty)	434	kg
Water content	60	
Dimensions		
Water connections (W1/W2)	DH65 PN16	-
Gas connection (G)	R1½"	-
Flue gas connection (D)	200	mm
Air intake connection (A) (for room sealed use)	130	mm
Condensate connection (S)	32	mm
Boiler length with water connection (L1)	1348	mm
Boiler length without water connection (L2)	1152	mm
Width	748.5	mm
Height (incl. cargo wheels)	1466	mm

* Calculated in accordance with Equation 2 in the Non-domestic Building Services Compliance Guide

** BREEAM UK New Construction 2018

Dimensions & Clearances:

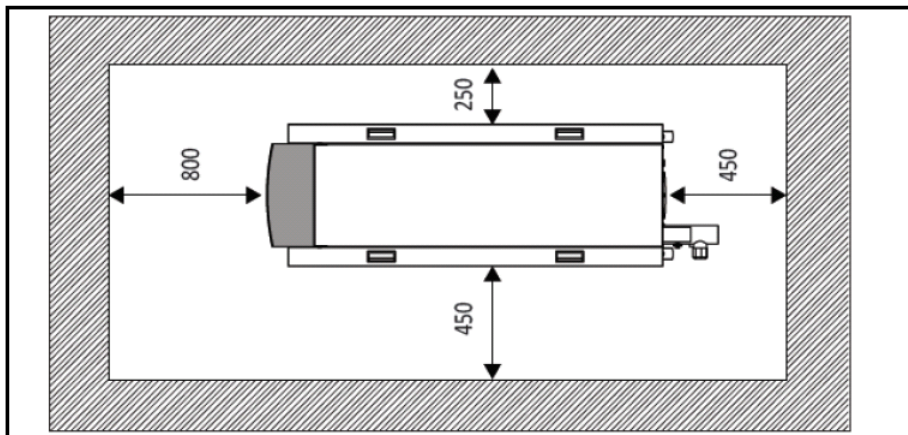
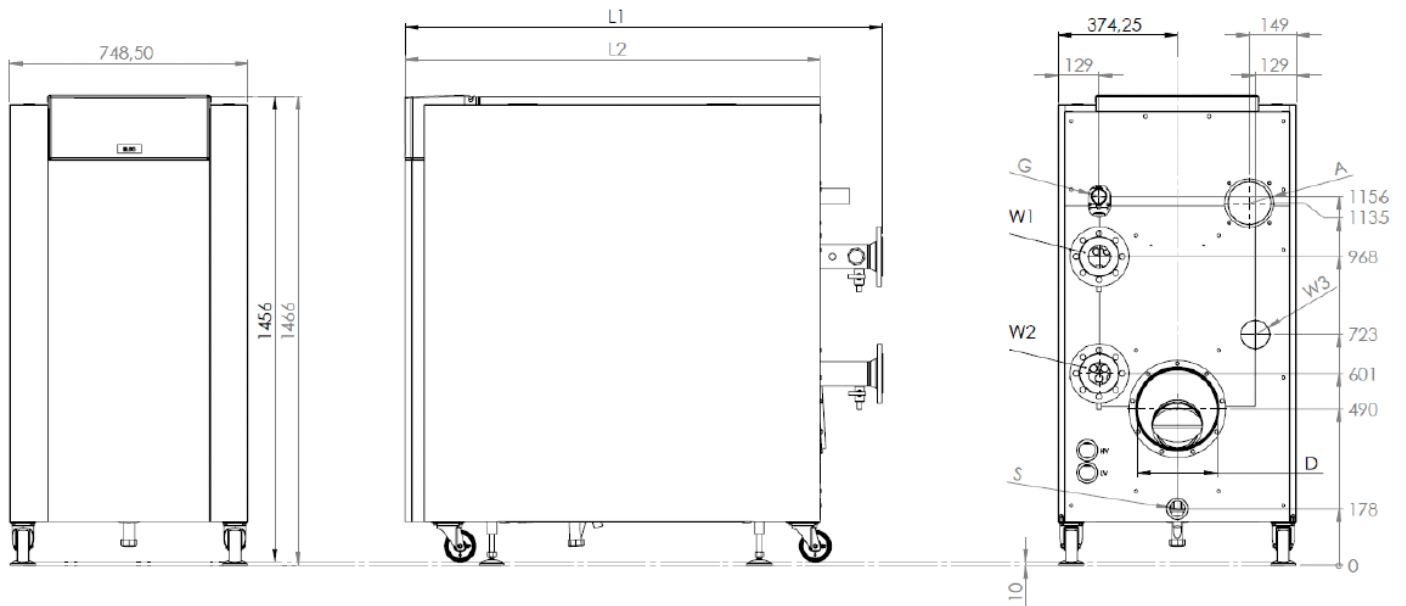

Dimensions mm	Trigon XL 300 H2
L1	1348
L2	1152
A - (combustion air supply)	130Ø
G - (gas connection)	1½"
D - (flue gas exhaust)	200Ø
S - (condense drain)	32
W1 - (primary flow)	DN65 PN16
W2 - (primary return)	DN65 PN16
W3 - (Optional - high temp return)	DN65 PN16

To optimize the position of the boiler in the room it is possible to exchange the position of the electrodes from the right side of the boiler to the left side of the boiler.

This also means that the required space as indicated in the picture will be mirrored.

Normal: Left 250mm / Right 450mm
Modified: Left 450mm / Right 250mm