

TECHNICAL SUBMISSION

Aerotop M24 – Air to Water Heat Pump

General Description:

The Aerotop M24 Air to Water heat pump is one of a range four units that provide heat outputs @ A-7 W35, ranging from 16.3kW to 31.1kW. The COP (EN14511:2018) at this condition ranges between 3.2 and 3.3 for all units. Multiple units can be installed with integral cascade control. The maximum number of units that can be controlled in a single cascade installation is sixteen. Elco Heating Solutions recommend installation of common primary flow and return manifolds for up-to four heat pumps in series. Installations of from four to sixteen can be installed in parallel banks of four to accommodate this feature.

The Aerotop M24 is supplied with modulating compressor and evaporator fan. This feature allows the units to accurately match the design loads and limit start/stop cycles. All models are reversible to provide the option of cooling during the summer months and incorporate integral defrost control. The units are designed for external installation

The heat pump is supplied in one piece with a fitted robust and stylish outer casing fabricated from steel, with zinc-magnesium coating. The final finish is polyester powder coat in RAL 9001. Each heat pump is supplied with an integral primary circulation pump on the system side of the condenser, an over-pressure relief valve, flow-proving switch, air vent and electric element. The case dimensions are compact and this ensures that the appliance takes minimal floor space. All units are supplied with anti-vibration mounts to limit transfer to the structure and a filter for installation in the primary return connection.

The heat pump is supplied with an integral control panel, that not only manages the operation of the unit but in addition, if required, can provide time and temperature control for a heating circuit, a domestic hot water circuit and a cooling circuit. The units can optionally be controlled via volt-free switching contacts and can accommodate Modbus communication for remote inputs and outputs to a building management system. The unit includes integral fault and alarm indications. Information is provided by specific fault codes and means less time in required fault finding.

The refrigerant circuit is hermetically sealed at manufacture.

The Aerotop M24 heat pump is a Keymark listed appliance.



INNOVATIVE AND SUSTAINABLE

Ambient air is used as the energy source
 Reversible heat pump using R32 refrigerant
 Can provide both heating and cooling

Warranty: To activate warranty, you must **register your product** within six months of the purchase date. This can be completed by telephone or email.

Tele: **0333 240 8777 option One** - New product registrations.

e-mail: **customer.service.uk@ariston.com**

The following information must be provided:

Appliance serial number

Purchase date

Installation date

Site contact name, email address and telephone number

Product installation address.

On the condition that the product has been installed to manufacturers instructions and the warranty terms and conditions have not been compromised, the **standard warranty term** for the **AERTOP M Heat Pumps** is **two years** from date of purchase.

All products that are **not registered**, will have a **one year** warranty period and this will cover **material and manufacture fault**, subject to the product being installed to manufacturers instructions.

Technical Data:

Aerotop Heat Pump	M24	
Compressor		
Compressor type	Rotary Inverter	-
Number of compressors	1	-
Oil charge	2.3	litres
Refrigerant type	R32	-
Refrigerant charge	7.9	kg
No of circuits	1	-
Primary Water Exchanger		
Type	Brazed plate heat exchanger	-
Water content	2.44	litres
Evaporator Fans		
Fan type	Variable speed Brushless DC motor	-
Number of fans	1	-
Standard air flow	3472	Litres/sec
Installed unit power	0.75	kW
Primary Water Circuit		
Maximum pressure	10	Bar
Minimum system water volume Heating	200	litres
Minimum system water volume Cooling	80	litres
Heat pump water content	5.44	litres
Minimum flow rate	0.9	litres/sec
Nominal flow rate 5°C ΔT @ output A7 W50	1.14	litres/sec
Maximum flow rate	2.6	litres/sec
Electrical Data		
Power Supply	400/3/50+N	V/P/Hz
Maximum full load current	20.0	Amps
Maximum full load power	12.08	kW
Maximum start current	20.0	Amps
Performance (EN14511:2018)		
Heating		
Operating condition A-7 W35 – COP – SCOP (W35)	16.3 – 4.17 – 4.3	kW – COP – SCOP
Operating condition A2 W35 – COP – SCOP (W35)	21.9 – 3.3 – 4.3	kW – COP – SCOP
Power consumption (EN14511:2018)	7.36	kW
Operating condition A-4 W50 – COP (UK Specific)	17.3 – 2.33	kW – COP
Cooling		
Operating condition A35 W18 – EER - SEER	31.3 – 4.12 – 4.63	kW – EER - SEER
Power consumption (EN14511:2018)	7.38	kW
General		
Operating weight	298	kg
Sound power – standard-Silent – Super Silent	75 – 74 - 72	dB(A)

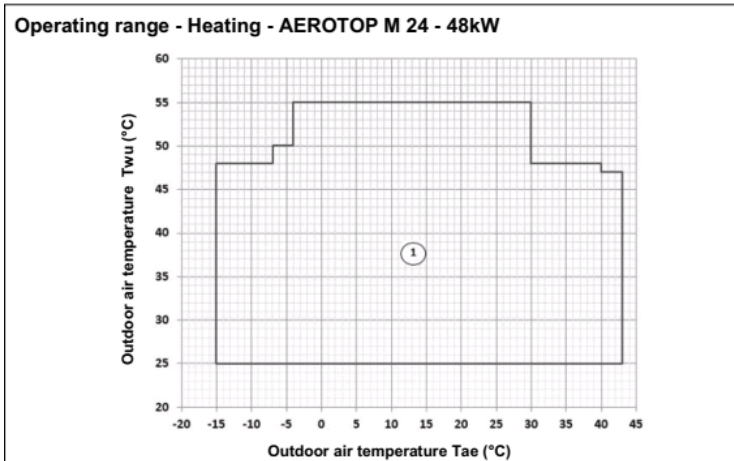

Operating Range – Heating

1. – Normal operating range

T_{wu} – Primary flow temperature

T_{ae} – Ambient air temperature

Operating range - Cooling AEROTOP M 24 - 48kW

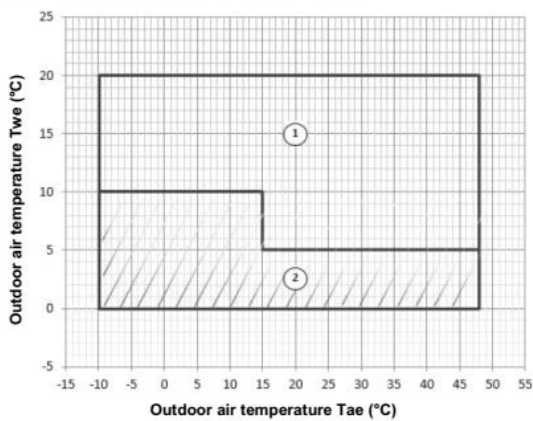

Operating Range – Cooling

1. – Normal operating range
2. – Operating range where the use of ethylene glycol is mandatory.

T_w – Primary flow temperature

T_a – Ambient air temperature

Heat Pump – Integral Components

1. Condenser/Evaporator – Plate heat Exchanger
2. Element for antifreeze protection
3. Temperature sensor
4. Flow proving switch
5. Over-pressure safety switch
6. Pressure gauge
7. Primary pump – adjustable frequency drive
8. Pressure relief valve
9. Discharge
10. Vent

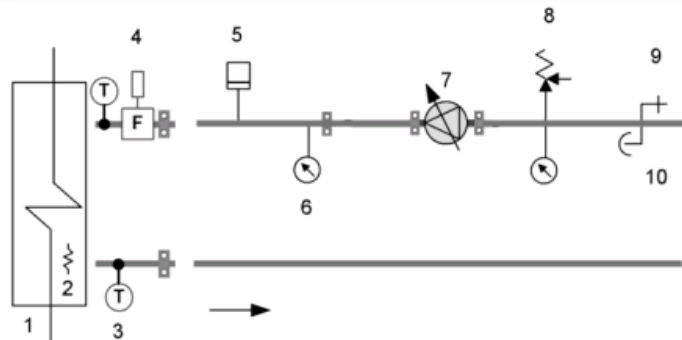

Note: A primary system water filter is supplied as a separate component and this should be installed in the primary return connection outside the appliance casing. The primary pipe-work should be connected to the heat pump using flexible connections (not supplied). This will isolate potential transmission of noise and eliminate stress transmission.

Dimension and Clearances

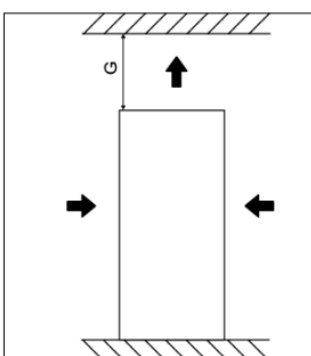
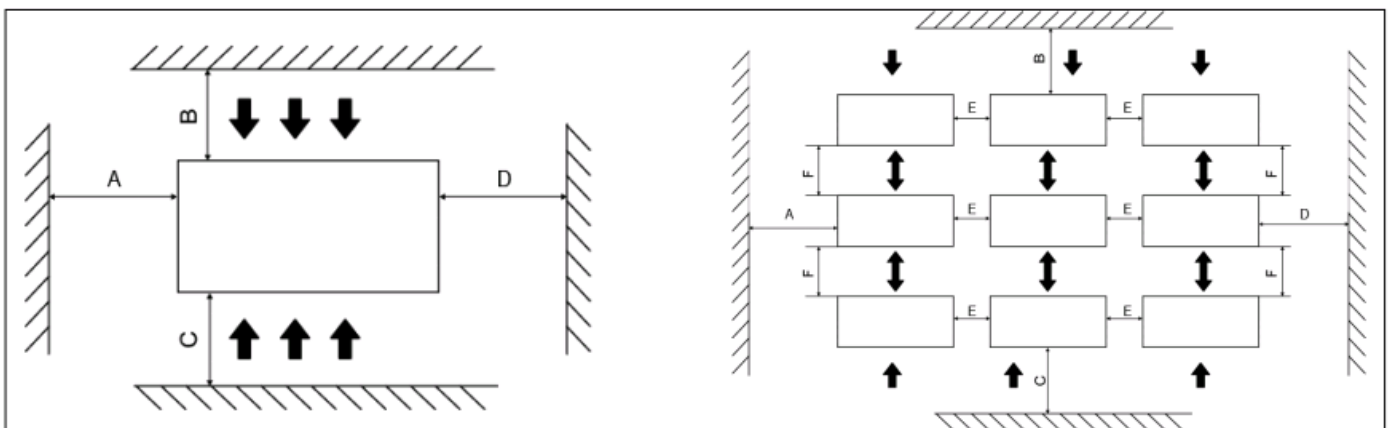

A	≥ 800 mm	E	≥ 800 mm
B	≥ 2000 mm	F	≥ 1100 mm
C	≥ 2000 mm	G	≥ 6000 mm
D	≥ 800 mm	/	/

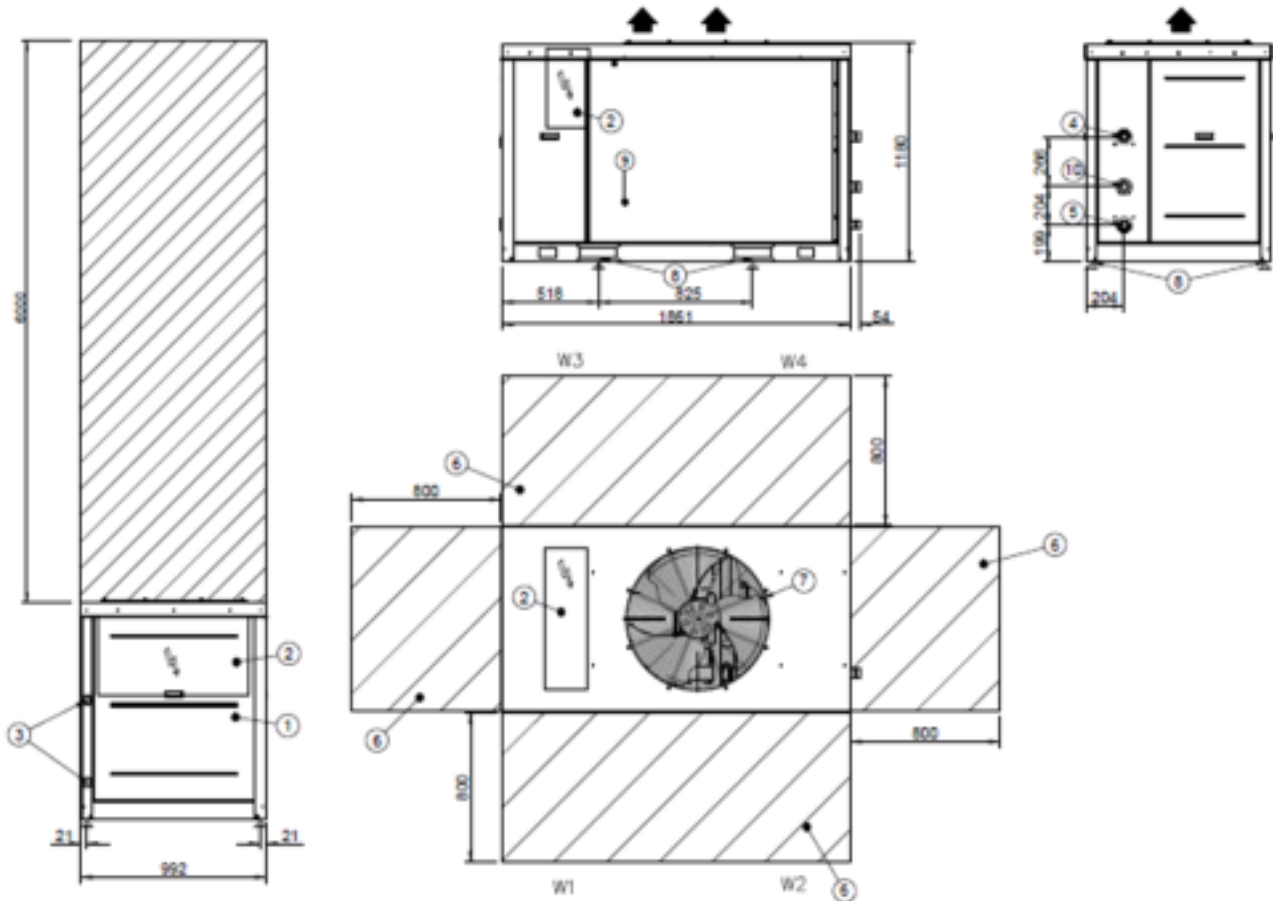

- 1. Compressor compartment
- 2. Electric panel
- 3. Control keypad
- 4. Power input
- 5. Primary Inlet (return) – 1½" Victaulic to 1½" BSP
- 6. Primary outlet (flow) – 1½" Victaulic to 1½" BSP
- 10. Primary pump
- 11. Clearance required

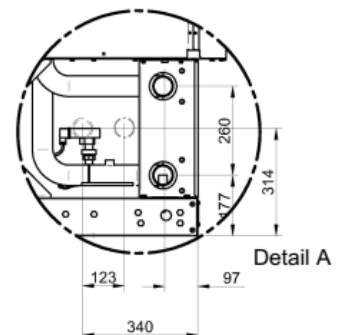
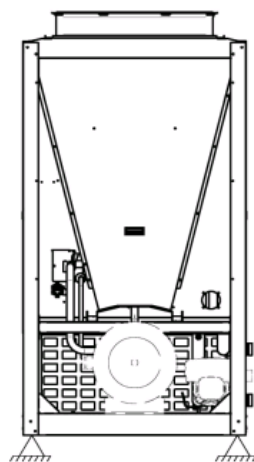

The connections at the heat pump are listed as Victaulic but threaded couplings are supplied with each heat pump

Elco Heating Solutions Limited www.elco.co.uk

3 Juniper West, Fenton Way, Southfields Business Park, Basildon SS15 6SJ 01268 546700